

CSA Consultation 25-402 on the Self-Regulatory Organization Framework

Brief submitted by the Groupe de recherche en droit des services financiers

Prepared by

Raymonde CRÊTE*, *Ad. E.*
Emeritus Professor
Emeritus Counsel
Codirector of the Groupe de recherche
en droit des services financiers
Faculty of Law
Université Laval

Cinthia DUCLOS*
Professor and Counsel
Codirector of the Groupe de recherche
en droit des services financiers
Faculty of Law
Université Laval

October 23, 2020

Table of Contents

Summary	3
Introduction	6
Part 1. An overview of intermediaries providing investment services	8
1.1 Investment dealer intermediaries.....	8
1.2 Mutual fund dealer intermediaries.....	8
1.3 Other intermediaries providing financial advisory services	9
Part 2. Regulatory issues of investment services provision	10
2.1 Product-based regulation	10
2.1.1 Convergence of services	10
2.1.2 Fragmentation of the current framework	11
1) The multiple regulatory authorities	11
2) Variability of investor protection plans	13
2.2 Investor confusion	14
Part 3. Towards a reform of investment services regulation	15
3.1 The guiding principles for reform	16
3.1.1 An integrated, simplified framework.....	16
3.1.2 A specialized, flexible framework	18
3.2 Proposed solutions.....	19
3.2.1 The IIROC’s proposal.....	19
3.2.2 The MFDA’s proposal	22
3.2.3 Comments on the proposals submitted by the SROs and other potential solutions..	23
Conclusion	26
Appendix 1 - Main GRDSF Publications	28
Appendix 2 - Table 1: Products and services by registration category.....	30
Appendix 3 - Diagram 1: The regulatory authorities in the investment services industry in Québec	31
Appendix 4 - Table 2: Regulation of investment services providers in Québec	32

Summary

Introduction

- As part the consultation process conducted by the Canadian Securities Administrators (**CSA**) on the self-regulatory organization framework, the purpose of this brief submitted by the *Groupe de recherche en droit des services financiers (GRDSF)* (research group on financial services law) is to enrich the debate surrounding some of the issues presented in the *Consultation Document 25-402* and to assess solutions that could improve the current legal framework.
- From the standpoint of protecting retail investors, our comments focus on investment services, i.e. investment advice, portfolio management, securities trading and financial planning.

Part 1. An overview of intermediaries providing investment services

- Investment dealers provide investment advice and trading services for all types of securities, including stocks, bonds, mutual funds, exchange-traded funds (**ETF**).
- Mutual fund dealers provide advisory and trading services for investment funds, mainly mutual funds.
- Other intermediaries offer investment services, including exempt market dealers, scholarship plan dealers, restricted dealers, advisors (portfolio managers), financial planning firms and intermediaries in the life insurance sector who provide advice and trade insurance investment products, such as segregated fund individual variable insurance contracts, commonly known as “segregated fund contracts”.

Part 2. Regulatory issues of investment services provision

- This part focuses on some of the issues addressed in the *Consultation Document* namely product-based regulation (**Issue 2**) and investor confusion (**Issue 5**).
- Research shows convergence of the investment services provided by intermediaries. Among those, advisory services represent a central core element for all the intermediaries.
- Despite the similarity of the services provided, the regulatory framework is currently based on a fragmented approach focused on products rather than on the activities of intermediaries.
- This fragmented framework is characterized by multiplication of regulatory authorities who establish various registration categories and sets of rules applicable to the intermediaries.
- These authorities include the following organizations:
 - The Investment Industry Regulatory Organization of Canada (**IIROC**) which regulates investment dealers, their managers and representatives providing services across Canada.
 - The Mutual Fund Dealers Association of Canada (**MFDA**) which regulates mutual fund dealers, their managers and representatives providing services across Canada, except in Québec.

- The Chambre de la sécurité financière (**CSF**) which is responsible for regulating mutual fund dealers' representatives, scholarship plan dealers' representatives, financial planners and representatives in insurance of persons doing business in Québec.
- Securities authorities, including the Autorité des marchés financiers (**AMF**) and Financial Markets Administrative Tribunal (**MAT**) in Québec, and the other provincial and territorial securities authorities in Canada that are part of the CSA. The AMF and the MAT regulate, among others, investment dealers, exempt market dealers, advisors (portfolio managers), scholarship plan dealers, financial planning firms and their representatives doing business in Québec.
- Among the negative impacts, this fragmented framework may lead to unequal protection for investors which is reflected in the different investor protection plans provided for in cases of insolvency or fraud by intermediaries. These plans vary depending on the registration category and the province where intermediaries do business.
- The investor protection plans include the Canadian Investor Protection Fund (**CIPF**) for investment dealers who are members of the IIROC and the MFDA Investor Protection Corporation (**MFDA IPC**) for mutual fund dealers regulated by the MFDA.
- In addition to these plans existing across Canada, there is, in Québec, the *Fonds d'indemnisation des services financiers (FISF)* which provides compensation for victims of fraud, fraudulent practices and embezzlement in respect of financial products or services provided by mutual fund dealers and scholarship plan dealers, representatives of such dealers, insurance firms and representatives, insurance adjusters, financial planners and mortgage dealers registered with the AMF.
- The multiple regulatory authorities and the various registration categories, sets of rules and investor protection plans can also create confusion among investors.

Part 3. Towards a reform of investment services regulation

- In this part, we present the guiding principles that could serve as a basis to assess the current regulatory framework and the reform proposals submitted by the IIROC and the MFDA and other solutions.
- Given the analysis standpoint of this brief, and as part of a reform, we recommend the creation of a regulatory framework with the following characteristics, namely **an integrated, simplified, specialized and flexible framework**, that will provide investor protection and maintain public trust in this core sector of the economy.
- In light of these guiding principles, the framework contemplated would maintain the self-regulatory model but should be designed using a coherent, holistic approach covering all investment sectors, i.e. investment advisory services, portfolio management services, securities trading services, financial planning services and life insurance services offering insurance-related investment products.
- This holistic approach should focus not on products but on the activities performed by the intermediaries who may offer similar services.
- An integrated framework should cover both the individual and organizational aspects of investment services provision, by giving the supervisory authorities jurisdiction over the three

groups of stakeholders (firms, their managers and representatives), as is currently the case for the IIROC and the MFDA.

- A specialized and flexible framework should also be able to adjust to the complex situations and constant changes that characterize the investment services industry in Canada.
- Based on these guiding principles, our analysis of the proposals submitted by the IIROC and the MFDA shows that both contain several aspects that echo the approach we recommend.
- If we compare the solutions proposed by the two bodies, the MFDA's solution appears to us to be more appropriate, in that it is more conducive to a holistic, simplified and flexible approach for regulating this sector of the financial services industry.
- The MFDA's proposal takes into account the specific situation of Québec, where the organization is not currently recognized by the AMF as a self-regulatory body, and where the CSF currently acts as a self-regulatory organization for representatives in the mutual fund and scholarship plan sectors and in other financial services sectors.
- In our comments of the MFDA's proposal with respect to the specific situation of Québec, we express some concerns that lead us to submit proposals with a view to improving the regulatory framework of investment services.

Conclusion

- Our analysis of the fragmented regulatory framework of investment services and the potential negative impacts of the current situation highlights the need to review the structure and content of the SROs' regulatory framework and the elements to be considered for the reform.
- Overall, we believe the proposals submitted by the IIROC and the MFDA offer some promising solutions that will help improve the self-regulatory organization framework.

Introduction

On June 25, 2020, the Canadian Securities Administrators (**CSA**) published the *CSA Consultation Paper 25-402 – Consultation on the Self-Regulatory Organization Framework* to obtain comments on the issues connected with the proposed review of the current framework for two self-regulatory organizations, the Investment Industry Regulatory Organization of Canada (**IIROC**), which regulates investment dealers and their representatives, and the Mutual Fund Dealers Association of Canada (**MFDA**), which regulates mutual fund dealers and their representatives.¹

The purpose of this brief is to enrich the debate surrounding some of the issues presented in the *Consultation Document* and to assess solutions that could improve the current framework. It focuses on investment services, i.e. investment advice, portfolio management, securities trading and financial planning.² In view of the scope of the consultation, our specialty fields and time constraints, our comments are mostly made from the standpoint of protecting retail investors.³

In the first part of the brief, we present an overview of the main intermediaries, and in the second part, we comment on two of the issues set out in the *Consultation Document*, namely **Issue 2**, on product-based regulation, and **Issue 5** on investor confusion. Consideration of these two issues reveals the fragmentation of the current framework and the need for a review. It also highlights the relevance of the proposed reform, and the need to contextualize the possible solutions presented in the third part of this brief.

Although this brief does not address any of the other issues identified by the CSA, we acknowledge, like the stakeholders surveyed by the CSA as part of the informal consultation process, that the current legal framework may be responsible for certain regulatory inefficiencies and a level of structural rigidity that is detrimental to stakeholders (investors, industry intermediaries, regulatory authorities, etc.), particularly in terms of the associated costs.

The comments made in this brief are based on research carried out since 2007 by the *Groupe de recherche en droit des services financiers (GRDSF)* (research group on financial services law) at the Faculty of Law of Université Laval, of which the brief's authors are members. The Group

* The authors thank Benjamin Waterhouse for the English translation of this brief. The authors also thank the members of the GRDSF who took part in a research program on dealers and financial advisors, whose publications served as a basis for this brief.

¹ CANADIAN SECURITIES ADMINISTRATORS, *Canadian Securities Administrators Consultation Paper 25-402– Consultation on the Self-Regulatory Organization Framework*, June 25, 2020, [Online]: <https://lautorite.qc.ca/fileadmin/lautorite/consultations/valeurs-mobilieres/2020-10/2020juin25-25-402-doc-consultation-oar-en.pdf> (*Consultation Document*).

² The term “investment services” covers a financial service sector that is not defined as such in Canada’s financial regulation. The term is used by the GRDSF researchers to refer to a set of services provided to address a growing need among consumers for investment advice to manage and grow their savings.

³ For the purposes of this brief, the term “retail investors” refers to individual clients or clients other than institutional investors, the latter mainly including financial institutions, retirement funds, investment funds and public bodies. “Retail investors” may also be referred to as “savers”, “clients” and “consumers”.

conducts research to understand and provide a critical assessment of the legal and organizational framework surrounding investment services.⁴

To simplify the text, the terms “intermediaries” and “registrants” are used to refer to firms and individuals offering investment services, including investment dealers, mutual fund dealers, restricted dealers, scholarship plan dealers, exempt market dealers, advisors (portfolio managers), financial planning firms and life insurance firms (for insurance investment products), and the representatives of all these different firms.

In addition, in the brief, the terms “regulatory authorities” and “supervisory authorities” are used to refer to securities authorities such as the Autorité des marchés financiers (**AMF**) and the Financial Markets Administrative Tribunal (**MAT**) in Québec, and the other provincial and territorial securities authorities in Canada that are part of the CSA. These terms also cover self-regulatory organizations (**SRO**), such as the IIROC, the MFDA, and the Chambre de la sécurité financière (**CSF**). These authorities, in their respective jurisdictions, exercise a variety of regulatory, administrative, enforcement and disciplinary powers over intermediaries providing investment services. Lastly, it should be noted that the observations set out in this brief are not intended as criticisms of individuals or regulatory authorities; their purpose is to enrich the debate and fuel thinking on how to improve the regulatory framework for the investment services industry and enhance the protection given to investors.

⁴ A list of the GRDSF’s main publications can be found in Appendix 1 to this brief.

Part 1. An overview of intermediaries providing investment services⁵

Before presenting our thoughts about the regulation set up by the SROs, we will begin by looking briefly at the investment dealers and mutual fund dealers that are subject to the regulation, and at the other intermediaries providing investment services in Canada.

1.1 Investment dealer intermediaries⁶

Investment dealers provide investment advice and trading services for all types of securities, including stocks, bonds, mutual funds, exchange-traded funds (ETF), exempt market products, futures contracts, derivatives and alternatives. These dealers may also provide discretionary portfolio management services by taking over asset management on behalf of investors. Their services may also be limited to trading services for order-execution only securities.⁷

1.2 Mutual fund dealer intermediaries⁸

Mutual fund dealers provide advisory and trading services for investment funds, mainly mutual funds.⁹ Unlike investment dealers, mutual fund dealers cannot offer investment products such as shares, bonds and derivatives. Similarly, they cannot offer certain services, such as the discretionary portfolio management services provided by investment dealers.

Most mutual fund dealers distribute investment fund products produced and managed by one of their affiliates in the same financial group. It should be noted that, today, most investment and mutual fund dealers work within corporate structures involved in an extensive range of financial

⁵ This part does not present some specific investment service industry intermediaries such as “investment fund managers”. For a detailed description of these intermediaries and the services they provide, see the *Consultation Document, supra*, note 1, p. 2-7; *Policy Statement to Regulation 31-103 respecting Registration Requirements, Exemptions and Ongoing Registrant Obligations* (including the most recent amendments in force on December 31, 2019), in part 7, p. 31-35; Raymonde CRÊTE and Cinthia DUCLOS, “Le portrait des prestataires de services de placement”, in R. CRÊTE, M. NACCARATO, M. LACOURSIÈRE and G. BRISSON (Eds.), *Courtiers et conseillers financiers - Encadrement des services de placement*, vol. 1, coll. CÉDÉ, Cowansville, Éditions Yvon Blais, 2011, p. 76 and following; Martin CÔTÉ, *Les mécanismes d’indemnisation des consommateurs dans l’industrie des services financiers au Québec*, vol. 5, coll. CÉDÉ, Montréal, Éditions Yvon Blais, 2015, p. 23 and following. For a summary profile of intermediaries, the services they offer and the products in respect of which they can act, see Table 1 (Appendix 2).

⁶ See the references cited in the previous note. See also Clément MABIT, *Le régime de sanctions disciplinaires applicable aux courtiers en placement*, vol. 2, coll. CÉDÉ, Cowansville, Éditions Yvon Blais, 2010. In addition, for a list of services provided by investment dealers, see Appendix 1 of the following text: IIROC, *Improving Self-Regulation for Canadians*, June 2020, p. 36, [Online]: https://www.IIROC.ca/Documents/2020/IIROC_consolidation_FNL.pdf. (consulted on September 24, 2020).

⁷ The terms “advice”, “trading” and “discretionary portfolio management” are defined in Table 1 (Appendix 2).

⁸ See the references in note 5. See also Raymonde CRÊTE and Cinthia DUCLOS, *Mémoire présenté à la Commission des finances publiques concernant le Projet de loi n° 141, Loi visant principalement à améliorer l’encadrement du secteur financier, la protection des dépôts d’argent et le régime de fonctionnement des institutions financières*, January 18, 2018; R. CRÊTE, C. DUCLOS and F. BLOUIN, “Les courtiers en épargne collective, leurs dirigeants et leurs représentants sont-ils à l’abri de sanctions disciplinaires au Québec?”, (2012) 42 *R.G.D.* 267, p. 333-341.

⁹ Mutual funds are part of the broader family of investment funds that also includes exchange-traded funds (ETF), hedge funds and labour funds or risk capital funds.

activities, including deposits and loans, insurance and securities (i.e. investment dealership, mutual fund dealership, portfolio management and investment fund management).¹⁰

1.3 Other intermediaries providing financial advisory services¹¹

In the securities sector, *National Instrument 31-103 Respecting Registration Requirements, Exemptions and Ongoing Registrant Obligations (National Instrument 31-103)*¹² provides for three other categories of dealers and representatives. The first category comprises exempt market dealers, authorized to act as dealers mainly by trading securities distributed under exemptions from prospectus requirements. The second comprises scholarship plan dealers, authorized to act as dealers in respect of scholarship plan, educational plan or educational trust securities. The third comprises restricted dealers, authorized to act as restricted dealers with respect only to specific securities categories, such as mining or gas sector shares. These intermediaries may provide advice and may trade specific products, depending on their registration categories, but like mutual fund dealers, they are not authorized to provide discretionary management services.

National Instrument 31-103 also provides for another registration category, “advisors” (also referred to as “portfolio managers”) and their representatives, providing personalized advisory services and, more broadly, portfolio management services. They prepare complete investment strategies for retail investors (especially the richer ones) and for institutional investors, including investment funds. Depending on their registration category (unrestricted or restricted), they can provide services with respect to a broad range of products, like investment dealers, but they are not authorized to engage in trading securities. However, if they wish to provide execution services to their clients, they may do so via a dealer.

In the financial services sector, there are also financial planning firms and financial planners (individuals) providing advisory services on a wide range of topics, including legal and estate issues, insurance, risk management, finance, taxation, investment and retirement. If they provide investment advice, it must be general in nature and must not concern the purchase or sale of specific securities. In addition, they cannot provide securities trading services or discretionary portfolio management services.

¹⁰ See Jean-Marc SURET and Cécile CARPENTIER (CIRANO), “Réglementation des valeurs mobilières au Canada”, working document prepared for the Commission des valeurs mobilières du Québec, Cirano, July 2003, p. 11, [Online]: <https://cirano.qc.ca/files/publications/2003RP-11.pdf> (consulted on September 23, 2020); Cinthia DUCLOS, *La protection des épargnants dans les services d’investissement: une étude des facteurs d’influence de nature organisationnelle des manquements professionnels à la lumière de l’étiologie des accidents*, Ph.D. thesis, Québec, Faculty of Law, Université Laval, 2019, p. 161 and following.

¹¹ See the references in note 5. For the life insurance sector, see also Martin CÔTÉ, “Le ‘contrat de fonds distincts’: un produit d’assurance à l’ombre du droit des valeurs mobilières ?”, (2019) 53 *RJTUM* 395, p. 409 and following.

¹² *National Instrument 31-103 Respecting Registration Requirements, Exemptions and Ongoing Registrant Obligations*, prepared in collaboration with IIROC and MFDA and adopted by the CSA, contains a detailed body of registration and conduct rules for several types of intermediaries offering investment services, including investment dealers, mutual fund dealers and their representatives.

Lastly, in the life insurance sector, firms and representatives offer life insurance products, individual annuities and other personal benefits. As part of this activity, they may provide advice and trade insurance investment products, including universal life insurance policies and segregated fund individual variable insurance contracts, commonly known as “segregated fund contracts”.¹³ Segregated funds are similar in some respects to the investment funds offered by investment dealers and mutual fund dealers.

Part 2. Regulatory issues of investment services provision

In this part, we focus on some of the issues addressed in the *Consultation Document* namely product-based regulation (**Issue 2**) and investor confusion (**Issue 5**). We begin by analyzing these issues from the standpoint of investor protection within the context of investment services for retail investors.

2.1 Product-based regulation

As pointed out in the *Consultation Document*, registrants in different registration categories “are providing similar products and services to similar clients but are overseen by different entities (i.e. the SROs and the CSA) and are subject to different rules.”¹⁴ This is especially true in Québec, due to the particular framework applicable to mutual fund dealers. More broadly, this problem also extends to other financial service intermediaries providing investment advice but not subject to the SRO in the securities sector (e.g. financial planners and life insurance representatives).

In the following paragraphs, we will look at two aspects of this problem, namely **convergence of services (2.1.1)** and **fragmentation of the current framework (2.1.2)**.

2.1.1 Convergence of services¹⁵

The GRDSF has found similarities among the services offered to investors by registrants in the different categories provided for in securities regulations and, more broadly, in the financial services sector in general. This convergence appears mainly in the supply of advisory services by different intermediaries for identical products, similar products and, more generally, different investment products.

Under the current regulation, registrants in different registration categories are permitted to provide advice on identical products. For example, investment dealers, mutual fund dealers, restricted

¹³ M. CÔTÉ (*Le contrat de fonds distincts*), *supra*, note 11.

¹⁴ *Consultation Document*, *supra*, note 1, p. 17.

¹⁵ See among others R. CRÊTE et C. DUCLOS (*Le portrait des prestataires*), *supra*, note 5, p. 108-115; M. CÔTÉ (*Les mécanismes d'indemnisation*), *supra*, note 5, p. 227-228; Raymonde CRÊTE, Martin CÔTÉ and Cinthia DUCLOS, “Un devoir légal, uniforme et modulable d’agir au mieux des intérêts du client de détail”, *Mémoire préparé pour l’Autorité des marchés financiers (AMF) et les Autorités canadiennes en valeurs mobilières (CSA)* on Consultation Paper 33-403 – *The Standard of Conduct for Advisors and Dealers : Exploring the Appropriateness of Introducing a Statutory Best Interest Duty When Advice is Provided to Retail Clients*, March 2013, p. 20-24.

dealers (depending on the circumstances) and advisors can provide advice on investment funds. This observation alone is sufficient to raise questions about product-based regulation.

Similarly, registrants in different registration categories can provide advice on products that are similar but not identical. For example, investment dealers can provide advice on mutual funds and ETFs, in the same way as advisors (portfolio managers) and restricted dealers, depending on the particular circumstances. Mutual fund dealers can do this with respect to mutual funds. As for life insurance representatives, they may provide advice on similar products in the insurance sector, such as segregated fund contracts. Lastly, financial planners may also provide advice, among other things to help clients clarify their financial goals for retirement and establish savings strategies that usually involve mutual funds and ETFs, or insurance-related investment products (including segregated fund contracts).

Overall, there is a lot of similarity between the advisory services available to investors, and some overlapping of the products with which intermediaries are permitted to work. This convergence is shown in **Table 1** (Appendix 2). More broadly, the table provides a summary of the functions of intermediaries by registration category in Québec. It clearly shows “advisory services” as a central core element for all the intermediaries.

2.1.2 Fragmentation of the current framework

The GRDSF’s research over the last decade shows that the current structure for distribution of securities and advisory services to investors is highly fragmented. Analysis of the fragmentation has focused mainly on the multiple regulatory authorities (including separate sets of rules and processes) and the variability of investor protection plans.

1) The multiple regulatory authorities

As the following profile shows, regulatory authorities in the investment advisory industry vary by registration category and by location in Canada.

Regulation of investment dealers and their representatives

The IIROC, recognized as an SRO by the CSA, regulates investment dealers, their managers and representatives operating in Québec and elsewhere in Canada. It establishes rules of conduct, as well as a disciplinary process including sanctions for infringements of the rules. The IIROC’s rules are completed by provincial and territorial securities regulation, including *National Instrument 31-103*.¹⁶

¹⁶ See *Consultation Document, supra*, note 1, p. 2-4, 37-40; Cinthia DUCLOS, with Raymonde CRÊTE and Audrey LÉTOURNEAU, “Les autorités d’encadrement”, in CRÊTE, R., M. NACCARATO, M. LACOURSIÈRE and G. BRISSON (Eds.), *Courtiers et conseillers financiers - Encadrement des services de placement*, vol. 1, coll. CÉDÉ, Cowansville, Éditions Yvon Blais, 2011, p. 137-144; C. MABIT, *supra*, note 6, p. 27-33.

Regulation of mutual fund dealers and their representatives

The MFDA, recognized as an SRO by securities authorities across Canada except in Québec, regulates mutual fund dealers, their managers and representatives. It establishes and implements a set of rules, along with a disciplinary process for infringements of the rules. The MFDA's rules are completed by securities regulation, including *National Instrument 31-103*.

In Québec, mutual fund dealer intermediaries are regulated by three authorities, namely the CSF, the AMF and the MAT. The CSF, as an SRO, is responsible for regulating mutual fund dealers' representatives in the province. This specific role is similar to that of the MFDA. However, unlike the MFDA, which has jurisdiction over all mutual fund stakeholders (dealers, managers and representatives), the CSF's jurisdiction is limited because, in the mutual fund sector, it does not regulate mutual fund dealers and their managers. It is responsible for applying and imposing disciplinary sanctions for infringements of the rules established by the AMF and by the Québec Government, mainly in the *Securities Act*, the *National Instrument 31-103*, the *Act respecting the distribution of financial products and services (ADFPS)* and the *Regulation respecting the rules of ethics in the securities sector*. Mutual fund dealers that do business solely in Québec, and their managers, are not subject to regulation by the CSF or any other SRO. At the present time, the *Consultation Document* notes that there are 19 mutual fund dealers registered solely in Québec.¹⁷ In the absence of an SRO for these intermediaries, the AMF and the MAT are responsible for regulating mutual fund dealers and some officers ("chief compliance officer" and "designated officer in charge") carrying out activities in Québec. These bodies must oversee compliance with the rules set out in Québec's securities legislation and regulations, including the *Securities Act* and *National Instrument 31-103*.¹⁸

Regulation of other intermediaries

Numerous other intermediaries, including scholarship plan dealers, restricted dealers, advisors (portfolio managers), financial planning firms and most of their respective managers and representatives are not governed by an SRO in Canada, but are generally subject to the CSA. In Québec, the CSF is responsible for regulating scholarship plan dealers' representatives, financial planners and representatives in insurance of persons, in the same way that it is responsible for mutual fund dealers' representatives.¹⁹

¹⁷ *Document de consultation, supra*, note 1, p. 45.

¹⁸ See *Consultation Document, supra*, note 1, p. 4, 5, 41-44; C. DUCLOS (*Les autorités d'encadrement*), *supra*, note 16, p. 144-149; R. CRÊTE and C. DUCLOS (*Brief Bill 141*), *supra*, note 8.

¹⁹ See *Consultation Document, supra*, note 1, p. 5-7; R. CRÊTE and C. DUCLOS (*Le portrait des prestataires*), *supra*, note 5, p. 90 and following; M. CÔTÉ (*Les mécanismes d'indemnisation*), *supra*, note 5, p. 23 and following.

Overview

In short, multiple authorities including the SROs, i.e. the IIROC, MFDA and CSF, along with the CSA, are responsible for regulating the intermediaries providing investment services in Canada, depending on their registration categories and the province where these intermediaries do business.

Table 2 (Appendix 4) reviews this structure as it exists in Québec.

To understand and visualize the problems arising from the existence of the different authorities, it is useful to consider the overall profile of the authorities with jurisdiction over intermediaries, including not only the SROs, but also the other regulatory authorities such as the AMF, MAT, etc., the organizations providing alternative dispute resolution mechanisms, and the investor protection funds. **Diagram 1** (Appendix 3) shows the connections between these authorities and their respective responsibilities over organizations and individuals providing investment services in Québec. The diagram clearly shows the complexity of the current regulatory framework and highlights the maze within which investors and the industry's intermediaries must function.

In closing, it is important to note that, at the present time, the overall profile of regulatory authorities is even more complex due to the structure of the financial services industry, characterized by the presence of financial groups providing different services within organizations or their subsidiaries, including finance services (deposits and loans), advisory services, discretionary portfolio management and securities trading services (investment dealers, mutual fund dealers, etc.), investment fund management, financial planning and insurance sector services.

2) Variability of investor protection plans²⁰

The fragmentation of the current regulatory framework often leads to unequal protection for investors. First, some intermediaries have dedicated SROs for their framework, essentially disciplinary in nature, while others are regulated only by the CSA with broader functions (regulatory, administrative, disciplinary and enforcement responsibilities for numerous participants in the capital markets and the financial sector). This difference also accentuates differences in the content of the regulatory framework (standards of conduct, processing of complaints, disciplinary processes) and in its application to the various intermediaries. More specifically, while the rules of conduct are intended to prevent misconduct by intermediaries, the level of detail and specificity of these rules differ depending on registration categories and the province where intermediaries do business. For example, the suitability requirements imposed on mutual fund dealers regulated by the MFDA are more detailed and cover more officers and managers (including branch managers) than those applicable to mutual fund dealers subject to regulation by the Québec authorities, and those applicable to certain other intermediaries not

²⁰ See R. CRÊTE and C. DUCLOS (*Le portrait des prestataires*), *supra*, note 5, p. 108-115; R. CRÊTE and C. DUCLOS (*Brief Bill 141*), *supra*, note 8; C. DUCLOS (*Les autorités d'encadrement*), *supra*, note 16, p. 120-128, 163-168; M. CÔTÉ (*Les mécanismes d'indemnisation*), *supra*, note 5, p. 90-173.

regulated by an SRO (including scholarship plan dealers, restricted dealers and advisors).²¹ Similarly, the level of detail, extent and nature of the disciplinary process and sanctions imposed also differ by registration category and region.

In addition, it is clear that the elements introduced to minimize the harm suffered by investors as a result of misconduct by intermediaries, including the complaint process and the investor protection funds, also vary by registration category. In Québec, for example, the *Fonds d'indemnisation des services financiers (FISF)* provides compensation for victims of fraud, fraudulent practices and embezzlement in respect of financial products or services provided by mutual fund dealers, scholarship plan dealers and representatives of such dealers, insurance firms and representatives, insurance adjusters, financial planners and mortgage dealers registered with the AMF. However, the FISF does not cover victims of fraud who dealt with an investment dealer or dealer's representative registered with the IIROC. For example, for the sale and purchase of mutual funds, if the service is provided by a mutual fund dealer, the investor will have access to the FISF in case of fraud, whereas if the same service is offered by an investment dealer, the investor will not have access to that or any other similar fund.

It is also important to note that, outside Québec, there is nothing similar to the FISF for victims of fraud who do business with an investment dealer or mutual fund dealer or one of their representatives. The IIROC and the MFDA each provide investors with an investor protection fund, but they only cover intermediary insolvency. The funds in question are the Canadian Investor Protection Fund (**CIPF**) for investment dealers who are members of the IIROC and the MFDA Investor Protection Corporation (**MFDA IPC**) for mutual fund dealers regulated by the MFDA. However, these two insolvency protection plans do not cover all intermediaries; among those not covered are exempt market dealers, advisors (portfolio managers) and scholarship plan dealers.

Table 2 (Appendix 4) presents the protection available to clients of the various intermediaries providing investment advisory services in Québec. It clearly shows that, although the services are the same, there are significant differences in the standards applicable to intermediaries, the regulatory bodies concerned and the protection afforded to investors, depending on registration category and region.

2.2 Investor confusion²²

In line with the observations set out in the *Consultation Document*, we note that the current fragmented and complex regulatory framework applicable to investment services is likely to create confusion among investors. Investors are offered numerous products and services, many of which are similar, by a host of intermediaries registered in different categories: for example, advisory

²¹ For a detailed analysis of this topic, see C. DUCLOS (*La protection des épargnants*), *supra*, note 10, p. 405 and following.

²² See *Consultation Document*, *supra*, note 1, p. 23-27; R. CRÊTE and C. DUCLOS (*Le portrait des prestataires*), *supra*, note 5, p. 108-115; C. DUCLOS (*Les autorités d'encadrement*), *supra*, note 16, p. 123-128; R. CRÊTE and C. DUCLOS (*Brief Bill 141*), *supra*, note 8.

services offered by investment dealers, mutual fund dealers, financial planners and life insurance representatives (e.g. segregated fund contracts). However, because of the sector's complex and compartmentalized structure, it is difficult for a lay person to distinguish between the different types of intermediaries, understand their functions and grasp the limits on the activities they are permitted to perform (with respect to services and products).

For example, an investor who entrusts his or her savings to a mutual fund dealer's representative may not understand the impacts of that choice; because of the registration category, the representative can only, or mainly, offer mutual funds, unlike an investment dealer's representative, who can offer a much broader range of products and services (shares, bonds, mutual fund products, ETF products, discretionary portfolio management, etc.). As a result, the investor may not be able to choose the products and services best suited to his or her needs and expectations.

Lay investors almost certainly know little to nothing about the duties of intermediaries in different registration categories (e.g. training and proficiency required by the various regulatory authorities and the rules to which they are subject). Similarly, retail investors will probably find it difficult to differentiate between the remedies and other mechanisms available in case of intermediary misconduct or insolvency; these elements will differ according to the intermediary's registration category. Lastly, although the products and services appear similar, these investors may find it hard to distinguish between the respective powers of the different regulatory authorities, such as the AMF, the MAT, the CSF, the IIROC and the MFDA, whose overseeing functions vary by intermediary registration category and geographic region. Generally speaking, the fact that investors do not understand these distinctions may make it difficult if not impossible to select the services that are not only best suited to their needs, but also provide the best protection (e.g. detailed standards of conduct, severe penalties for misconduct, a compensation fund in case of fraud, etc.).

Overall, the issues considered above reveal a fragmented regulatory framework characterized by similarity of services, multiplication of regulatory authorities and a variety of investor protection plans, all of which, when combined, are likely to create confusion among investors and adversely affect their interests. Consideration of these issues highlights the need to review the structure and content of the SROs' framework and the elements to be considered for the reform.

Part 3. Towards a reform of investment services regulation

The following section presents the guiding principles that could serve as a basis to reform and review the current regulatory framework for investment services. These same guiding principles can also serve to assess the solutions submitted by the IIROC and the MFDA, and other possible reforms.

3.1 The guiding principles for reform

In the highly complex and diverse world of investment services, the regulatory authorities acknowledge the need for professionalism because of the required expertise for providing these services, the high level of client trust, dependency and vulnerability with respect to the intermediaries, and the significant risk that consumers' interests may be harmed.²³ Regulation of these services is therefore a significant challenge for the authorities aware of the need to minimize these risks.

Given the analysis standpoint of this brief, and as part of a reform, we recommend the creation of a regulatory framework with the following characteristics, namely **an integrated, simplified framework (3.1.1)** and **a specialized, flexible framework (3.1.2)**, that will provide investor protection and maintain public trust in this core sector of the economy. Although this brief does not address all the issues raised in the *Consultation Document*, we, like other observers of the financial services industry,²⁴ acknowledge the need to create a regulatory framework that will also foster regulatory and business efficiency. Similarly, we believe the implementation of a reform, beyond the elements presented in this brief, will demand a complementary analysis of the related economic, political and social issues.

3.1.1 An integrated, simplified framework

An “integrated framework” is designed to be holistic and coherent as opposed to a fragmented and partitioned approach. This framework should cover all investment services, i.e. investment advice, portfolio management, securities trading and financial planning. As other observers have suggested during proposed reforms of the financial sector, this holistic approach should focus not on products but on the activities performed by the intermediaries who may offer similar services.²⁵ It should also take into account the expectations of investors, who want easy, low-cost access to a broad range of investment products and services to grow their savings, along with consistent legal protection to ensure that their assets are safe.²⁶ Some observers have proposed a “one-stop”

²³ R. CRÊTE, M. LACOURSIÈRE and C. DUCLOS, “La rationalité du particularisme juridique des rapports de confiance dans les services de placement”, in R. CRÊTE, M. NACCARATO, M. LACOURSIÈRE and G. BRISSON (Eds.), *Courtiers et conseillers financiers – Encadrement des services de placement*, vol. 1, Coll. CÉDÉ, Cowansville, Éditions Yvon Blais, 2011, p. 229-273.

²⁴ IIROC (*Improving self-regulation*), *supra*, note 6, p. 23, 29; MFDA/MFDA, *A Proposal for a Modern SRO – Special Report on Securities Industry Self-Regulation*, Feb. 2020, p. 4, 6, 16, 18, 21, 25 and following., [Online]: https://mfda.ca/wp-content/uploads/MFDA_SpecialReport.pdf (consulted on September 24, 2020).

²⁵ See MFDA/MFDA (*A Proposal for a Modern SRO*), *supra*, note 24, p. 9, 22; ONTARIO SECURITIES COMMISSION, *The Fair Dealing Model*, 2004, [Online]: https://www.osc.gov.on.ca/documents/en/Securities-Category3/cp_33-901_20040129_fdm.pdf (consulted on September 24, 2020); GROUPE DE TRAVAIL SUR L'ENCADREMENT DU SECTEUR FINANCIER (Gouvernement du Québec), *Pour un encadrement intégré et simplifié du secteur financier au Québec*, Québec, Ministère des Finances, 2001 (**Rapport Martineau**).

²⁶ IIROC (*Improving self-regulation*), *supra*, note 6, p. 7-9.

scenario covering both supply of products and services by a single financial enterprise and the application of monitoring and control powers by a single regulatory authority.²⁷

As part of the proposed approach, consideration should be given not only to the investment services available in the securities sector, but also to the products offered in the life insurance sector, including segregated funds. Currently, although life insurance products resemble the investment funds offered in the securities sector, the regulation governing the distribution of segregated fund contracts in the insurance sector are not the same as those applicable to the distribution of investment funds in the securities market.²⁸ In other words, the existence of these different regulatory frameworks perpetuates partitioning of similar products available through different distribution channels, and enhances the possibility of regulatory arbitrage.²⁹

Second, the integrated structure we recommend covers both the individual and organizational (or systemic) aspects of investment services.³⁰ With respect to the regulation of intermediaries, from an administrative, disciplinary, civil or penal standpoint, it is important for the regulator or the supervisory authority to be able to act holistically, taking into account both the direct supply of services to investors and the leadership, management and supervision of the firm providing the services.

For example, in a case of professional misconduct by an investment dealer's representative, the supervisory authority should be able to verify whether the misconduct was also a result of supervisory failures by the managers of the firm for which the representative worked. The authority should be able to impose a sanction on the firm and perhaps even on certain members of its management if it uncovers weaknesses in the firm's monitoring and compliance mechanisms. A regulatory structure overseeing three groups of stakeholders (firms, management and representatives) should therefore be responsible for examining both the individual and the organizational aspects of investment services.³¹

Lastly, a "simplified" framework refers to a framework that simplifies regulatory structures and content in order to avoid or minimize duplication, redundancy and administrative or financial burdens, as well as the risk of confusion arising from the existence of numerous regulatory

²⁷ Regarding the proposed "one-stop" approach for regulatory authorities, see the *Rapport Martineau*, *supra*, note 25, p. iii and chapter 8.

²⁸ M. CÔTÉ, *supra*, note 11, p. 13-43.

²⁹ The term "regulatory arbitrage" means "an activity in which registrants can exploit differences in regulatory frameworks to their advantage, in ways that the Securities Regulators did not intend": *Consultation Document*, *supra*, note 1, p. 17. It has also been defined as a situation "where loopholes in regulatory systems are used to circumvent unfavourable regulation". SEE CCIR/CCRA, *Segregated Funds Working Group – Position Paper*, December 2017, p. 25, [Online]: <https://www.ccir-ccra.org/Documents/View/3369> (consulted on October 16, 2020).

³⁰ C. DUCLOS (*La protection des épargnants*), *supra*, note 10; R. CRÊTE and C. DUCLOS (*Brief Bill 141*), *supra*, note 8; R. CRÊTE, C. DUCLOS and F. BLOUIN, *supra*, note 8, p. 333-341, 402, 411-418.

³¹ C. DUCLOS (*La protection des épargnants*), *supra*, note 10; R. CRÊTE and C. DUCLOS (*Brief Bill 141*), *supra*, note 8, p. 7, 9, 28, 29, 35, 38, 39.

authorities, intermediary categories and sets of rules. A simplified framework will help promote efficiency by ensuring that implementation costs do not exceed the anticipated benefits.

To create an integrated, simplified structure, it will also be necessary to restructure the regulators, through enhanced inter-authority coordination, de-partitioning and simplification of registration categories for intermediaries and harmonization of the regulation.

3.1.2 A specialized, flexible framework

The regulation contemplated should be designed to adequately reflect the complexity and diversity of the investment services industry. The framework must therefore be both specialized and flexible, and must, among other things, take into account the differences between types of investors, firms' business models, the products and services offered, the associated risks, and specific regional aspects. In the constantly evolving world of financial services, the regulation must also be able to adapt efficiently to technological innovations and to the frequent changes in the sector.

A specialized, flexible framework must also be workable in the different economic, social and legal environments in which the industry's stakeholders operate. To achieve this, it should involve local regulatory authorities with the specific expertise and experience needed to adapt the regulation to the differences and features of a given environment (e.g. in Québec, the specificity of a legal system based on civil law tradition and the promotion of the French language).

The self-regulatory model would be an appropriate basis for this specialized, flexible platform. As pointed out in the literature on the choice of regulatory methods, this model is justified by the expertise, flexibility and proximity of the SROs, since they are able to adapt regulation to the realities of the regulated industry.³² Self-regulation may, however, raise some concerns, in particular with regard to SRO governance.³³ As pointed out by some of the stakeholders surveyed by the CSA, the involvement of investment services industry members in the SROs may increase the risk of industry capture and partiality, thereby undermining public trust in the SROs.³⁴ While acknowledging the relevance of these concerns and the need for them to be considered, we nevertheless believe that this regulatory method would produce a more specialized platform. We also point out that, for the purposes of this brief, our analysis of potential solutions is limited, since

³² Simon ROMANO, "Self-Regulation in the Securities Industry – A Regulatory Perspective", (1995) 18 *OCSB* 4824, p. 4 ; Christine FAY and Nicolas PARENT, "La structure de la réglementation des marchés financiers: survol de la littérature", *Revue du système financier*, p. 62, [Online] <http://www.banqueducanada.ca/wp-content/uploads/2012/01/rsf-0604-fay.pdf>. (consulted on September 24, 2020); Margot PRIEST, "The Privatization of Regulation: Five Models of Self-Regulation", (1997-1998) 29 *Ottawa L. Rev.* 233, p. 268-271; Peter DEY and Stanley MAKUCH, "Surveillance gouvernementale des organismes autorégulateurs dans l'industrie des valeurs mobilières au Canada", in INDUSTRIE CANADA, *Avant-projet d'une loi canadienne sur le marché des valeurs mobilières*, vol. 3, Consommation et Corporation Canada, p. 1626-1631.

³³ *Consultation Document*, *supra*, note 1, p. 27 and following.

³⁴ *Idem*.

it focuses on the aspects applicable to the regulatory authority's jurisdiction, over different types of intermediaries and the general structure of the regulation applicable to those intermediaries.

3.2 Proposed solutions

As pointed out earlier, Canada currently has several different self-regulatory organizations to oversee investment services. Surveillance of pan-Canadian services is carried out mainly by two SROs, namely the IIROC for investment dealers and their representatives, and the MFDA for mutual fund dealers and their representatives outside Québec.³⁵ The other intermediaries providing investment advisory and portfolio management services, including exempt market dealers, advisors (portfolio managers), and scholarship plan dealers and their representatives, are not covered by SROs, but are subject instead to surveillance by the CSA as part of their broader mandate.³⁶

Québec has another SRO, the CSF, which is mainly responsible for discipline and continuous training of mutual fund dealers' representatives, scholarship plan dealers' representatives, representatives in insurance of persons and financial planners. Since the CSF is only responsible for surveillance and control of representatives, i.e. individuals who work in the sectors concerned, the AMF and the MAT provide complementary regulation and are responsible for supervising the firms themselves, i.e. mutual fund dealers, scholarship plan dealers, financial planning firms, insurance firms and insurers.³⁷

The IIROC and the MFDA are aware of the problems arising from the multiple SROs that exist in Canada, and have submitted proposals to improve the self-regulatory model. An overview of these proposals is presented below. Due to time constraints, we will not consider some aspects addressed in the proposals, namely questions concerning SRO governance and the structuring of market surveillance activities.

3.2.1 The IIROC's proposal

In a document published in June 2020, entitled *Improving Self-Regulation for Canadians*, the IIROC suggests that it should merge with the MFDA in order to reduce the regulatory burden and associated costs, prepare flexible regulation adjusted to the firms' different business models and respond more effectively to investors' needs.³⁸ Under the proposal, the new SRO would comprise two divisions within the same organization: one to be responsible for investment dealers and the other for mutual fund dealers. There would be two sets of rules, one applicable to registrants under each of these divisions. In addition, at least in the early stages, the two dealer insolvency protection plans would also be maintained, providing coverage for cases currently covered by the CIPF for

³⁵ See the above text in section 2.1.2, especially with regard to the number of supervisory authorities.

³⁶ Investment dealers and their representatives, as well as mutual fund dealers and their representatives outside Québec are also subject to surveillance by the CSA as part of their broader mandate. See Diagram 1 in Appendix 3.

³⁷ See Table 2 in Appendix 4.

³⁸ IIROC (*Improving Self-Regulation*), *supra*, note 6.

IIROC members and by the MFDA IPC for MFDA members.³⁹ However, the proposal also noted that the protection offered by the two plans should eventually be harmonized.

Under the terms of the proposal, dealers and their representatives would continue to carry out the same activities and be subject to separate regulation for each of the merged SRO's divisions, depending on the nature of those activities. Alternatively, dual-platform dealers, i.e. those currently registered with both SROs and subject to both regulatory platforms, could "choose to consolidate all their representatives in a single legal entity, etc., with each activity regulated in proportion to its risk".⁴⁰

One of the main benefits of the merger would be for dual-platform dealers, whose regulatory burden and associated costs would be reduced as a result. As the IIROC document explains: "This would allow investment dealers to introduce a mutual fund-only offering within their existing legal entity without having to establish a separate dealer on the MFDA platform."⁴¹ Merging the SROs would also allow mutual fund dealers and their representatives to enter more easily into agreements with investment dealers in order to expand their supply of products by distributing ETF products.⁴²

In addition, the merger would allow the authorities to continue, as they already do, to cover both the individual and organizational aspects of investment services provision, while providing a specialized framework for the three groups of stakeholders (firms, management and representatives) as we recommend in the guiding principles set out earlier.

Although we recognize these benefits and those identified by the IIROC in its document, the proposal nevertheless has some limitations. First, the organization resulting from the merger would still maintain two separate bodies of regulation, one for each division. Unless it makes a significant effort to harmonize and consolidate these rules, continuation of the dual system would do little to eliminate the overlaps and redundancies identified by critics of the current system.

There are also questions concerning the obligations imposed on mutual fund dealers' representatives who may decide to join an investment dealership. In its proposal, the IIROC notes that, if the two SROs were to merge, "clients would not have to re-open accounts and/or change firms/advisors as their investing needs change."⁴³ This begs the following question: if mutual fund representatives are hired by an investment dealer, could they offer products other than investment fund products, along with a discretionary portfolio management service, in order to address their clients' changing needs? If so, would these representatives be required to previously fulfill additional proficiency requirements? If not, if mutual fund representatives were to maintain their current activities, would the clients who do business with them have to change intermediaries if

³⁹ IIROC (*Improving Self-Regulation*), *supra*, note 6, p. 26.

⁴⁰ *Idem*, p. 18.

⁴¹ *Idem*, p. 14.

⁴² *Idem*, p. 16, 18.

⁴³ *Idem*, p. 20.

they subsequently want access to a broader range of products and services to meet their changing needs?

The IIROC proposal also raises questions concerning the limited jurisdiction of the SRO resulting from the merger, which would not cover all the intermediaries offering investment services, but only investment dealers, mutual fund dealers and their representatives. Exempt market dealers, advisors (portfolio managers), scholarship plan dealers and financial planning firms and their representatives, most of which are currently subject to regulation by the CSA, would be excluded. It also seems that, in the case of investment services provided in Québec, the CSF would continue to be the supervising body for mutual fund dealers' representatives, scholarship plan dealers' representatives, financial planners and representatives in insurance of persons offering segregated fund contracts among other things. The AMF and the MAT would also continue to be responsible for regulating firms in these same sectors.

In short, the IIROC's merger proposal has benefits that would, in some respects, help to simplify the regulatory burden of registrants by creating a more flexible platform that could be adjusted to different business models, and by providing access to a more extensive range of products for investors and better coordination of the regulatory functions of the SRO resulting from the merger. On the other hand, the existence of two divisions, one for investment dealers and the other for mutual fund dealers, would maintain the current registration categories and would still require two bodies of rules, each applicable to one of the two divisions.

The merger proposal also is of limited scope in that it excludes regulation of mutual fund dealer intermediaries operating solely in Québec and regulation of other intermediaries offering investment services. In addition, at least in the early days, the IIROC would maintain the two existing insolvency protection plans (the CIPF and the MFDA IPC). In addition to these two plans, the FISF would also be maintained in Québec to compensate victims of fraud who did business with a mutual fund dealer, a mutual fund representative, a scholarship plan representative or an insurance representative registered with the AMF.⁴⁴

Overall, the merger proposal would maintain several elements of the current compartmentalized platform. Regarding the guiding principles set out earlier, the proposed solution, at least in the short and medium terms, would not produce the changes required to create an integrated, simplified platform such as we recommend. However, its "step by step" approach does offer an interesting way forward in that it lays the groundwork for longer-term implementation of a general platform that would cover all intermediaries providing investment services in Canada, to minimize the problems arising from the multiple regulatory authorities, sets of rules and investor protection regimes.

⁴⁴ Regarding the FISF, see section 2.1.2, in particular on the variability of investor protection plans.

3.2.2 The MFDA's proposal

The reform proposed by the MFDA involves more extensive structural and regulatory changes than the IIROC's proposal.⁴⁵ Compared to the IIROC's proposal, which recommends merging two SROs to create a single entity with two separate divisions, the MFDA proposes the creation of a new SRO (*NewCo*), with a more comprehensive field of action. The new SRO proposed by the MFDA would be responsible for regulating different types of intermediaries providing investment services, including investment dealers, mutual fund dealers, advisors (portfolio managers), exempt market dealers and scholarship plan dealers, along with their respective representatives.⁴⁶ The MFDA's proposal also provides for the creation of a protection plan (or more than one plan) to cover the risks associated with the products and services provided by these intermediaries, including the risks currently covered by the CIPF and the MFDA IPC.⁴⁷ The MFDA's proposal, while suggesting an integrated platform for all intermediaries providing investment services, also takes into account the particular situation of Québec, where the MFDA is not currently recognized as an SRO by the AMF. We will come back to this question in more detail in the next section.

According to the MFDA's proposal, the main purpose of the new self-regulatory organization would be to protect the public interest by taking into account "in a fair and balanced way" the interests of the various stakeholders, including investors, industry participants, regulatory authorities, governments and Canadian society in general.⁴⁸ The new organization's regulatory action would also be based on the principle that similar activities would be subject to similar regulations so that investors have the same level of protection regardless of the registrant with whom they deal.⁴⁹

The reform proposed by the MFDA includes some major changes that echo the integrated, simplified, specialized and flexible model we propose in this brief. From a structural standpoint, the new SRO would cover a broader range of intermediaries than the merger organization proposed by the IIROC, including not only the intermediaries subject to regulation by the current SROs (IIROC and MFDA), i.e. investment dealers, mutual fund dealers and their representatives, but also those regulated by the CSA, i.e. exempt market dealers, advisors (portfolio managers), scholarship plan dealers and their representatives.

A new, integrated organization covering all these intermediaries, as suggested by the MFDA, would continue to cover both individual and organizational aspects of investment services provision, and would also maintain specialized regulation, like the organization resulting from the merger proposed by the IIROC.

⁴⁵ MFDA (*A Proposal for a Modern SRO*), *supra*, note 24.

⁴⁶ *Idem*, p. 5.

⁴⁷ *Idem*, p. 23.

⁴⁸ *Idem*, p. 16.

⁴⁹ *Idem*, p. 9, 18.

From a regulatory standpoint, the MFDA's proposal is also consistent with the guiding principles set out in this brief, since it suggests a review of registration categories based on a holistic supply of financial advisory services, rather than an approach based on the sale of specific products or limited service supplies, as is currently the case.⁵⁰ Rather than two separate bodies of rules, as suggested by the IIROC, there would be one integrated set of rules that could be tailored to the range of situations existing in the industry, to take into account different business models, products, experiences and regional requirements, as well as broader public policy considerations.⁵¹

In closing, it should be noted that the MFDA's proposal, like that made by the IIROC, does not address the regulation of intermediaries in the financial planning and life insurance sectors.

3.2.3 Comments on the proposals submitted by the SROs and other potential solutions

The current SROs propose a number of structural and regulatory changes based mainly on the self-regulatory model, to modernize and improve the regulation of certain types of intermediaries offering investment services throughout Canada. Generally speaking, the solution proposed by the MFDA, namely the creation of a new SRO that would regulate a broader range of intermediaries and the introduction of common, activity-focused regulation, seems to be more promising in that it leans more towards a holistic, simplified, flexible approach. In comparison, it is difficult to reconcile this approach with the IIROC's proposal to maintain two separate divisions and two separate bodies of rules because, at least in the short and medium terms, the consolidated SRO contemplated by IIROC would maintain the current fragmentation by focusing on the products offered by intermediaries. However, we are aware that a reform similar to that recommended by the MFDA would present some significant challenges for all the stakeholders concerned, which would have to work together to achieve the aims of the process.

As mentioned earlier, the MFDA's proposal takes into account the specific situation of Québec, where the organization is not currently recognized by the AMF as a self-regulatory body, and where the CSF currently acts as a self-regulatory organization for representatives in the mutual fund and scholarship plan sectors.⁵² The MFDA is aware of this and suggests that the new, integrated organization could enter into a cooperation agreement with these Québec organizations, as is currently the case, so as not to change the CSF's role and operations. At the same time, the MFDA suggests that the formal recognition for the new organization as an SRO in Québec could also be considered.⁵³

Assuming that the new SRO is not formally recognized by the AMF, mutual fund intermediaries with activities in Québec and elsewhere in Canada would continue to be regulated by four organizations, namely the AMF, the MAT, the CSF and the new pan-Canadian SRO. This aspect

⁵⁰ MFDA/MFDA (*A Proposal for a Modern SRO*), *supra*, note 24, p. 9, 22.

⁵¹ *Idem*, p. 19.

⁵² *Idem*, p. 23.

⁵³ *Idem*.

of the MFDA's proposal is troubling, since it would perpetuate the problems arising from the existence of too many regulatory authorities.

If the new SRO does not obtain AMF recognition for mutual fund intermediaries, this would also have the effect of maintaining a weakness in the current regulatory framework in Québec, which results in a division of responsibility for the sector between three different organizations, namely the AMF, the MAT and the CSF.⁵⁴

Under the current regulatory regime for this sector, the AMF and the MAT regulate mutual fund dealer firms and some of their officers (the "chief compliance officer" and "designated officer in charge"), while the CSF is responsible only for disciplinary regulation of representatives, i.e. individuals.⁵⁵ Given the CSF's limited jurisdiction over the individual aspects of services provision, it cannot address organizational misconduct i.e. misconduct by the firms and by the officers and managers of the firms for which the representatives work.⁵⁶ This means that if the CSF identifies misconduct in the organizational environment, it cannot discipline either the firm or the officers and managers that failed to provide the required surveillance. Currently, only the AMF and the MAT have jurisdiction over organizational aspects.

Therefore, where misconduct occurs within a mutual fund dealership, the three authorities (the AMF, the MAT and the CSF) may become involved in the inspection, investigation, complaint and disciplinary process. In our view, this is a weakness of the current platform. Accordingly, the MFDA's proposal to maintain this aspect of Québec's current platform is not consistent with the integrated approach we propose, which should cover both the individual and the organizational aspects of investment services by regulating all three groups of stakeholders (firms, managers and representatives).

With this in mind, one of the solutions that might be considered is to extend the jurisdiction of the new SRO proposed by the MFDA to cover regulation of mutual fund dealers operating in Québec and elsewhere in Canada.⁵⁷ Extending the jurisdiction of this new SRO, which would be

⁵⁴ The potential solutions for the regulation of the mutual fund sector were raised during consultations on Bill 141, on the reform of the financial sector, in 2017. See R. CRÊTE and C. DUCLOS (*Brief Bill 141*), *supra*, note 8, p. 26 and following. See also the consultations organized by the AMF during the registration reform that came into force in 2009: AMF, *Consultation on the regulatory framework applicable to the mutual fund sector further to the registration reform project*, February 20, 2007, [Online]: http://www.lautorite.qc.ca/files/pdf/reforme-inscription/epargne-collective/consultation-1/Document_consultation.pdf (consulted on September 24, 2020); AMF, *Consultation on the harmonization of mutual fund distribution regulations*, October 1, 2010, p. 5, [Online]: <http://www.lautorite.qc.ca/files/pdf/consultations/valeurs-mobilieres/2010oct01-cons-epargnecoll-doc-fr.pdf> (consulted on September 24, 2020).

⁵⁵ C. DUCLOS (*La protection des épargnants*), *supra*, note 10, p. 379 and following; R. CRÊTE and C. DUCLOS (*Brief Bill 141*), *supra*, note 8, p. 5, 7, 20, 21; R. CRÊTE, C. DUCLOS and F. BLOUIN, *supra*, note 8, p. 333-341, 411-418.

⁵⁶ *Idem*.

⁵⁷ Formal recognition of the MFDA as a SRO in Québec has already been considered during the consultations organized by the AMF in 2007 and 2010, see the references cited in note 54.

responsible for overall regulation of most investment services sector intermediaries, would help to reduce the problems arising from the current multiple regulatory authorities.

If this avenue were to be chosen, we would need to ask ourselves if the concentration of regulatory, surveillance and control powers in a single SRO with pan-Canadian jurisdiction would remove the benefits of regulation by local bodies such as the AMF, the MAT and the CSF in Québec. These authorities have developed expertise in and experience of financial services regulation that allows them to consider the economic, social and legal aspects specific to Québec. In practical terms, this means they can establish standards and exercise their surveillance and control powers with due regard for Québec's civil law tradition and promotion of the French language.

To address these concerns, the proposed reform could maintain the benefits of local regulation by including provincially established sector-based structures within the new SRO. These structures could be managed by qualified personnel with appropriate expertise and experience in the province concerned. This would allow the personnel members to play an active role in developing and implementing the regulation. It is also worth noting that, under the proposals submitted respectively by the IIROC and the MFDA, the CSA would still exercise the new SRO's surveillance and control powers, as they currently do for the existing SROs.

Rather than expanding the jurisdiction of the new SRO proposed by the MFDA to include regulation of mutual funds' representatives working in Québec, an alternative solution would be to expand the powers of the CSF and recognize it as an SRO for regulating the three groups of mutual fund stakeholders (dealers, managers and representatives) working in Québec.⁵⁸ This solution would also maintain the CSF's benefits in Québec, including local surveillance, qualified personnel and overall regulation of representatives in the sectors governed by the *Act respecting the distribution of financial products and services*. However, the fact of expanding the CSF's powers in the mutual fund sector would do nothing to avoid regulatory duplication for dealers and representatives working in Québec and elsewhere in Canada, because the new SRO proposed by the MFDA would be required to intervene in activities outside Québec. The two organizations could enter into a cooperative agreement for the preparation and implementation of the regulatory platform, and in particular for the introduction of a coordinated inspection, investigation and disciplinary process.

In preparing and implementing the regulation, it is important to note that the current SROs, namely the IIROC and the MFDA, have, in recent years, developed detailed rules applicable throughout Canada to investment dealers, mutual fund dealers and their representatives, and that they have

⁵⁸ C. DUCLOS (*La protection des épargnants*), *supra*, note 10, p. 403; R. CRÊTE, C. DUCLOS and F. BLOUIN, *supra*, note 8, p. 418. As an alternative solution, Bill 141 on the reform of the financial sector, tabled in 2017, provided for the abolition of the CSF and the Chambre de l'assurance de dommages (ChAD), and the transfer of their powers to the AMF and the MAT. This potential solution was not retained when the bill was finally passed. Regarding this proposal, see R. CRÊTE and C. DUCLOS (*Brief Bill 141*), *supra*, note 8, p. 6, 7, 8, 26 and following.

worked closely with the CSA to adopt and enforce harmonized regulation applicable to these intermediaries, including *National Instrument 31-103*. In this regard, a new SRO that is responsible for regulating intermediaries in Canada would be able to use qualified and experienced people from both these organizations to draw up the new pan-Canadian regulation and exercise oversight powers in each province with due regard for local characteristics.

Conclusion

Based on the work we have done as members of the GRDSF, we agreed enthusiastically to take part in the CSA consultation on the SRO framework, by contributing to the debate on some of the issues presented in the *Consultation Document* and assessing some potential solutions to improve the regulation of investment services offered by a broad range of intermediaries. Our comments in this brief are made from the standpoint of investor protection.

Our analysis, like that of many other observers, shows that the current framework is based on a fragmented approach focused on products rather than on the activities of intermediaries. This compartmentalized platform has led to the creation of multiple authorities, each with different registration categories and sets of rules, and this despite the similarity of the services provided. One of the negative consequences of this fragmentation is that it leads to unequal protection for investors, especially with regard to the application of the protection plans in cases of insolvency or fraud, which vary by registration category and region. Our analysis also reveals that the various regulatory authorities, the range of registration categories and sets of rules, and the existence of different protection plans, is likely to create confusion among investors.

These observations highlight the need to review the structure and content of the current SRO framework. In the consultation process organized by the CSA, we therefore consider it necessary to put forward certain guiding principles in order to assess the solutions submitted by the IIROC and the MFDA for an eventual reform. From the analysis standpoint used in this brief, these principles include the creation of an integrated, simplified, specialized, flexible framework to protect investors and maintain public trust in the financial service sector.

More specifically, this framework, based on the self-regulatory model, should be designed using a coherent, holistic approach covering all investment sectors, i.e. investment advisory services, portfolio management services, securities trading services, financial planning services and life insurance services offering insurance-related investment products. As proposed by other observers, this approach would focus on intermediaries' activities rather than products, and would take similarity of services into account. It would help minimize or avoid duplications, variability of protection plans and administrative or financial burdens, and would minimize the risk of confusion generated by the multiple regulatory authorities, registration categories and rules. The integrated framework contemplated here should also cover both the individual and organizational aspects of investment services by giving the supervisory authorities jurisdiction over the three

groups of stakeholders (firms, managers and representatives), as is currently the case for the IIROC and the MFDA. Lastly, the framework should be both flexible and specialized, and should be able to adjust to the complex situations and constant changes that characterize the investment services industry in Canada.

Based on these guiding principles, our analysis of the proposals submitted by the IIROC and the MFDA shows that both contain several aspects that echo the approach we recommend. If we compare the solutions proposed by the two bodies, the MFDA's solution appears to be more appropriate, in that it is more conducive to a holistic approach for regulating this sector of the financial services industry, subject, however, to the concerns and alternatives we have presented for some aspects of investment services regulation in Québec. Overall, we believe the proposals submitted by these two pan-Canadian SROs are interesting and offer some promising solutions that will help improve the regulatory framework.

Monographs, collective works and other publications

BRISSON, G., P. TACHÉ, H. ZIMMERMANN, C. MABIT et R. CRÊTE, *La réglementation des activités de conseil en placement. Le point de vue des professionnels*, vol. 3, coll. CÉDÉ, Cowansville, Éditions Yvon Blais, 2010, 186 p.

CÔTÉ, M., *Les mécanismes d'indemnisation des consommateurs dans l'industrie des services financiers*, vol. 5, coll. CÉDÉ, Montréal, Éditions Yvon Blais, 2015, 273 p.

CRÊTE, R., M. CÔTÉ et C. DUCLOS, avec la collab. de M.-J. NORMAND-HEISLER, « Un devoir légal, uniforme et modulable d'agir au mieux des intérêts du client de détail », *Mémoire préparé pour les Autorités canadiennes en valeurs mobilières (CSA) dans le cadre de la consultation 33-403*, mars 2013, 43 p.

CRÊTE, R., et C. DUCLOS, *Commentaires soumis aux Autorités canadiennes en valeurs mobilières*, concernant le Document de consultation 33-404 des Autorités canadiennes valeurs mobilières – *Propositions de rehaussement des obligations des conseillers, des courtiers et des représentants envers leurs clients* (28 avril 2016), Québec, 30 septembre 2016, 26 p.

CRÊTE, R., et C. DUCLOS, *Mémoire présenté à la Commission des finances publiques concernant le projet de no 141, Loi visant principalement à améliorer l'encadrement du secteur financier, la protection des dépôts d'argent et le régime de fonctionnement des institutions financières*, 18 janvier 2018, 53 p.

CRÊTE, R., et C. DUCLOS, *Réflexions sur l'encadrement des services de courtage en épargne collective*, mémoire soumis dans le cadre de la consultation sur le *Rapport sur l'application de la Loi sur la distribution des produits et services financiers*, Québec, 30 septembre 2015, 52 p.

CRÊTE, R., et C. MORIN (dir.), *La protection juridique des personnes âgées contre l'exploitation financière*, *Revue générale de droit*, 2016, vol. 46, 529 p. (numéro hors série).

CRÊTE, R., et C. MORIN, *Mémoire de la Chaire Antoine-Turmel pour la Consultation des Autorités canadiennes en valeurs mobilières (CSA) sur le Projet de modification visant à rehausser la protection des clients âgés et vulnérables*, déposé auprès de l'Autorité des marchés financiers (AMF), le 20 juillet 2020, 30 p.

CRÊTE, R., I. TCHOTOURIAN et M. BEAULIEU (dir.), *L'exploitation financière des personnes âgées: prévention, résolution et sanction*, Cowansville, Éditions Yvon Blais, 2014, 542 p.

CRÊTE, R., M. LACOURSIÈRE, M. NACCARATO et G. BRISSON (dir.), *La confiance au cœur de l'industrie des services financiers*, Cowansville, Éditions Yvon Blais, 2009, 483 p.

CRÊTE, R., M. NACCARATO, M. LACOURSIÈRE et G. BRISSON (dir.), *Courtiers et conseillers financiers. Encadrement des services de placement*, vol. 1, coll. CÉDÉ, Cowansville, Éditions Yvon Blais, 2011, 720 p.

DUCLLOS, C., *La protection des épargnants dans les services d'investissement : une étude des facteurs d'influence de nature organisationnelle des manquements professionnels à la lumière de l'étiologie des accidents*, thèse de doctorat, Québec, Faculté de droit, Université Laval, 2019, 521 p. (Publication aux Éditions Yvon Blais à venir).

LÉTOURNEAU, A., *Le contrat de service, le mandat et le régime de l'administration du bien d'autrui : similitudes, incidences et différences dans le contexte des services d'investissement*, mémoire de maîtrise, sous la direction de Raymonde Crête, janvier 2013, 176 p.

MABIT, C., *Le régime de sanctions disciplinaires applicable aux courtiers en placement*, vol. 2, coll. CÉDÉ, Cowansville, Éditions Yvon Blais, 2010, 177 p.

PARADIS, J., *La rémunération des acteurs de l'industrie de l'épargne collective au regard de la protection des épargnants*, vol. 4., coll. CÉDÉ, Montréal, Éditions Yvon Blais, 2015, 230 p.

Papers in journals and collective works

CÔTÉ, M., « Le « contrat de fonds distincts » : un produit d'assurance à l'ombre du droit des valeurs mobilières ? », (2019) 53 *RJTUM* 395-459.

CRÊTE, R., « Les manifestations du particularisme juridique des rapports de confiance dans les services de conseils financiers et de gestion de portefeuille », (2009) 39 *R.G.D.* 581-653.

CRÊTE, R., « La difficile cohabitation des impératifs économiques des gestionnaires de patrimoine et des intérêts des épargnants », dans *Les conflits d'intérêts*, Journées nationales, Association Henri Capitant, t. 17, Lyon, Dalloz, 2013, p. 153-171.

CRÊTE, R., C. DUCLOS et F. BLOUIN, « Les courtiers en épargne collective, leurs dirigeants et leurs représentants sont-ils à l'abri de sanctions disciplinaires au Québec? », (2012) 42 *R.G.D.* 267-446.

CRÊTE, R., et C. MORIN, « La protection juridique des personnes âgées contre l'exploitation financière », (2016) 46 *R.G.D.* 5-11.

CRÊTE, R., et M. CÔTÉ, « La reconnaissance juridique de la spécificité des services de gestion de patrimoine dans l'industrie des fonds d'investissement », dans T. GRANIER (dir.), *Les fonds d'investissement*, coll. Axe Droit, Paris, Lamy, 2013, p. 19-45.

CRÊTE, R., M. LACOURSIÈRE et C. DUCLOS, « La rationalité du particularisme juridique des rapports de confiance dans les services de conseils financiers et de gestion de portefeuille », (2009) 39 *R.G.D.* 523-580.

CRÊTE, R., M. NACCARATO, C. DUCLOS, A. LÉTOURNEAU et C. MABIT, « L'encadrement légal et les types de déviations dans les services de placement », (2010) 35:2 *Gestion* 35-48.

CRÊTE, R., M. NACCARATO, C. DUCLOS, A. LÉTOURNEAU et C. MABIT, « Les déviations dans les services de placement : responsabilités, sanctions et moyens de prévention », (2010) 35 *Gestion* 49-60.

DUCLOS, C., et F. LÉVESQUE, « L'incidence de l'âge et de la vulnérabilité de la victime dans l'évaluation de sa part de responsabilité dans le préjudice subi : l'exemple des services financiers », (2016) 46 *R.G.D.* 219-276.

NACCARATO, M., et A. LÉTOURNEAU, « La confiance trahie : La répression pénale et criminelle du manquement contractuel de l'intermédiaire de marché en valeurs mobilières et la détermination des peines applicables », (2010) 43 *R.J.T.* 145-270.

APPENDIX 2 - Table 1: Products and services by registration category⁵⁹

		Investment dealer and representatives	Mutual fund dealer and representatives	Other dealers and representatives	Advisor (portfolio manager) and representatives	Financial planning firm and financial planners	Life insurance firm and representatives
Functions and activities	Definition / Products	All products	Mutual fund products	Specific products according to their registration category	All products (subject to restrictions)	All products	Segregated fund contracts
Trading	Action through which financial instruments are traded (purchased and sold).	Authorized	Authorized	Authorized	Not authorized	Not authorized	Authorized
Advice	Recommendations made and opinions offered on what should be done or the provision of an intellectual contribution aimed at offering guidelines, selecting actions or assisting with decisions on different operations.	Authorized	Authorized	Authorized	Authorized	Authorized (only for general advice)	Authorized
Discretionary portfolio management	Portfolio management contract under which the intermediary has extended powers to select and carry out operations without obtaining prior consent from the client.	Authorized	Not authorized	Not authorized	Authorized*	Not authorized	Not authorized

* With assistance from a dealer for securities trading.

⁵⁹ Table based on the table presented in R. CRÊTE and C. DUCLOS (*Le portrait des prestataires*), *supra*, note 5, p. 109.

APPENDIX 3 - Diagram 1: The regulatory authorities in the investment services industry in Québec⁶⁰

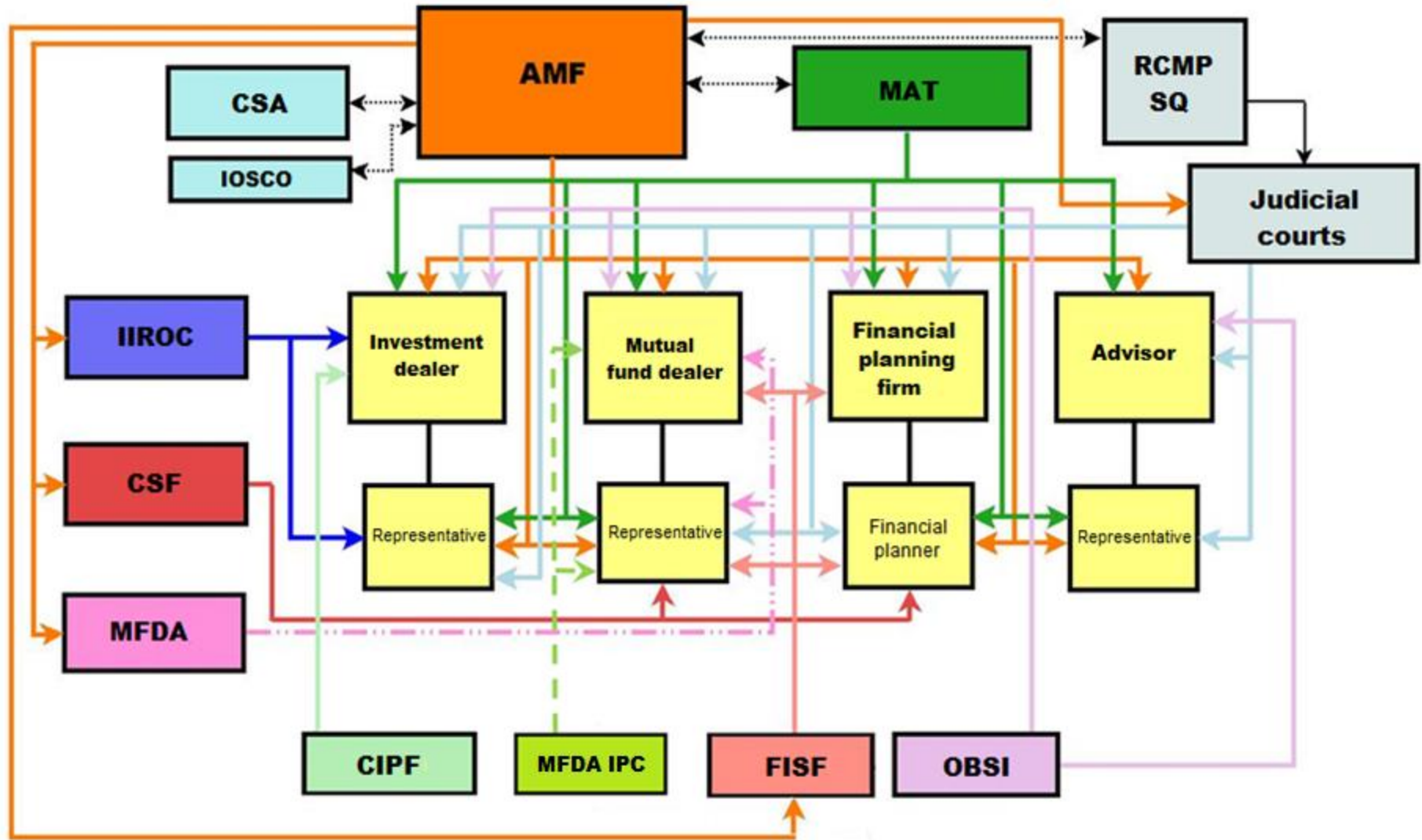

⁶⁰ Diagram updated in 2020. See C. DUCLOS (*Les autorités d'encadrement*), *supra*, note 16, p. 128.

APPENDIX 4 - Table 2: Regulation of investment services providers in Québec⁶¹

		LEGAL REGULATION						
		Rules	Administrative bodies and administrative tribunals	Self-regulatory organizations	Body with disciplinary jurisdiction	Body with ethics jurisdiction	Compensation fund for clients	Alternative dispute resolution mechanisms
		Main sources of rules*	Regulation of the right to practice, awarding of licences, and imposition of penalties	Regulation by members of an activity sector (specific and adapted to that sector)	Enforcement: follow-up of complaints, investigations, hearings	Preparation of rules of conduct and inspections to ensure enforcement	Compensation for consumers in case of insolvency, fraud, etc. (varies by fund)	Mediation, conciliation and arbitration services
CATEGORIES OF INTERMEDIARIES	Investment dealers and their representatives	SA, NI 31-103, SR, Rules of member dealers-IIROC	AMF, MAT, IIROC (for registration)	IIROC	IIROC	IIROC	CIPF	AMF IIROC (OBSI)
	Mutual fund dealers	SA, NI 31-103, SR (MFDA rules)	AMF, MAT	- (MFDA)	AMF, MAT (MFDA)	AMF (MFDA)	FISF (MFDA IPC)	AMF (OBSI) (MFDA)
	Mutual fund dealers' representatives	SA, ADFPS ⁶² , NI 31-103, SR, RRESS (MFDA rules)	AMF, MAT	CSF (MFDA)	CSF	AMF / CSF	FISF (MFDA IPC)	AMF (OBSI) (MFDA)
	Other dealers and their representatives	SA, NI 31-103, SR, RRESS ⁶³	AMF, MAT	-	AMF, MAT	AMF	-	AMF
	Advisors and their representatives	SA, NI 31-103, SR	AMF, MAT	-	AMF, MAT	AMF	-	AMF
	Financial planning firms	ADFPS, RRFRIIP	AMF, MAT	-	AMF, MAT	AMF	FISF	AMF (OBSI)
	Financial planners	ADFPS, CSF code of ethics, RPAR, IQPF rules	AMF, MAT	CSF, IQPF	CSF	CSF	FISF	AMF
	Firms (personal insurance)	ADFPS, RRFRIIP	AMF, MAT	-	AMF, MAT	AMF	FISF	AMF
	Personal insurance representatives	ADFPS, CSF code of ethics, RPAR	AMF, MAT	CSF	CSF	CSF	FISF	AMF

* *Securities Act*, CQLR, c. V-1.1 (SA); *Securities Regulation*, CQLR, c. V-1.1, r. 50 (SR); *Regulation respecting the rules of ethics in the securities sector*, CQLR, c. D-9.2, r. 7.1 (RRESS); *Regulation respecting the registration of firms, representatives and independent partnerships* CQLR, c. D-9.2, r. 15 (RRFRIIP); *Regulation respecting the pursuit of activities as a representative* CQLR, c. D-9.2, r. 10 (RPAR).

⁶¹ Table based on R. CRÊTE and C. DUCLOS (*Le portrait des prestataires*), *supra*, note 5, p. 113. The elements shown in brackets are applicable mainly to intermediaries that also have activities outside Québec.

⁶² Only some sections of the ADFPS are applicable to mutual fund dealers' representatives. See SR, s. 149.2; ADFPS, Division V to VI.

⁶³ Only for scholarship plan dealers' representatives.